

MONO-TUBE BUILDINGS

The Mono-Tube Rushmore Building has been constructed from 2 3/8-inch to 3-inch 12-gauge galvanized tubing to create a strong, affordable and secure environment. This wall mounted building provides a safe environment for a number of applications including machinery, commodities, and general warehousing.

RUSH-Co MAKES REPLACEMENT COVERS FOR ALL BRANDS!

Benefits of the Mono-Tube Building

- Easy to assemble
- 12.5 oz woven high-density polyethylene coated fabric cover
- Connecting hardware is zinc-plated to resist corrosion
- Ratchets offer a secure tie-down
- End walls and doors are available
- Cover draws over the framework in minutes
- No internal columns to interfere with moving machinery
- Huge energy saving due to little or no daytime lighting needs
- 15-year limited warranty on the cover and a 5-year limited warranty on the frame
- Low cost per square foot as compared to other building types



24' MONO-TUBE BUILDING

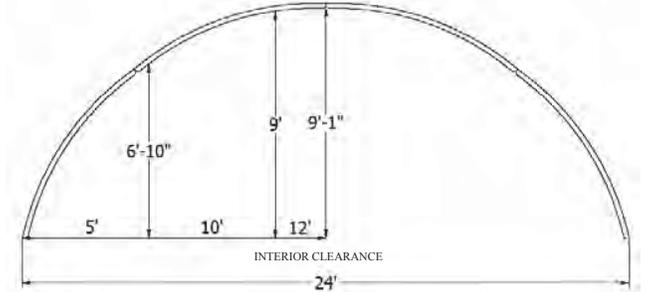

30' MONO-TUBE BUILDING

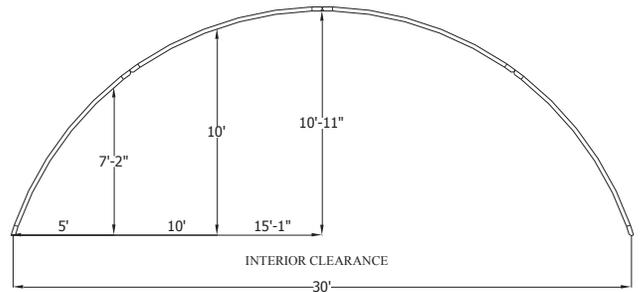

36' MONO-TUBE BUILDING

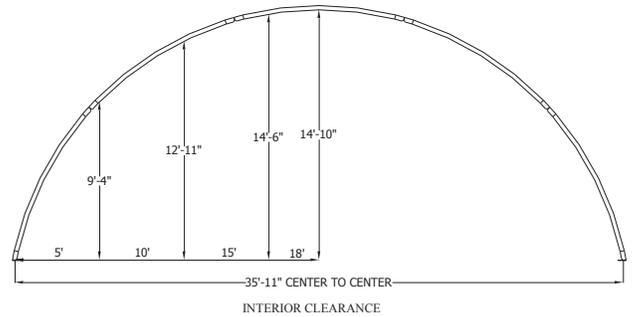

WWW.RUSH-CO.COM • Rush-Co Rushmore Buildings Catalog • Rush-Co reserves the right to change products as required

TRUSS BUILDINGS

Engineered to meet or exceed local snow and wind loads, this in-line galvanized steel truss building is the workhorse of Rushmore Buildings. These buildings are designed to protect your investments from the fiercest environment. The Rush-Co Truss Building is the best solution for the smart buyer. The Truss Building provides a safe, secure environment for any application — grain, salt, sand, job site equipment, machinery and livestock.

RUSH-CO MAKES REPLACEMENT COVERS FOR ALL BRANDS!

Benefits of the Truss Building

- We can customize buildings for many situations. Our standard widths are 36, 40, 44, 45, 50, 60, 70, 80, 100, 120, and 140 feet.
- 12.5 oz woven high-density polyethylene coated fabric cover
- All connecting hardware and metal components are zinc-plated to resist corrosion
- Ratchets offer a secure tie-down system that offers the most secure hold down system in the industry
- Cover draws over the framework in minutes
- No internal columns to interfere with moving machinery
- Huge energy saving due to little or no daytime lighting needs
- 15-year limited warranty on frame and cover
- Low cost per square foot as compared to other building types
- Offered in hot dipped galvanized for highly corrosive applications such as salt and fertilizer

WWW.RUSH-CO.COM • Rush-Co Rushmore Buildings Catalog • Rush-Co reserves the right to change products as required

36' TRUSS BUILDING

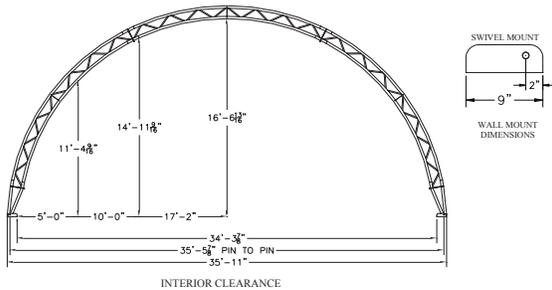

40' TRUSS BUILDING

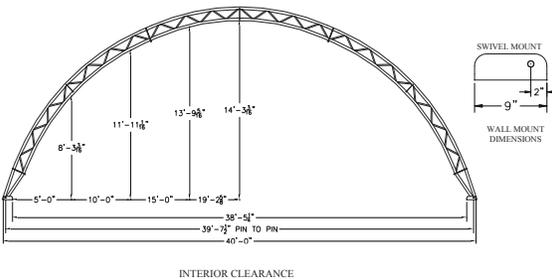

44' TRUSS BUILDING

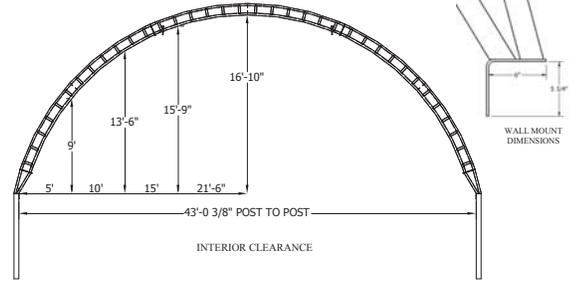

45' TRUSS BUILDING

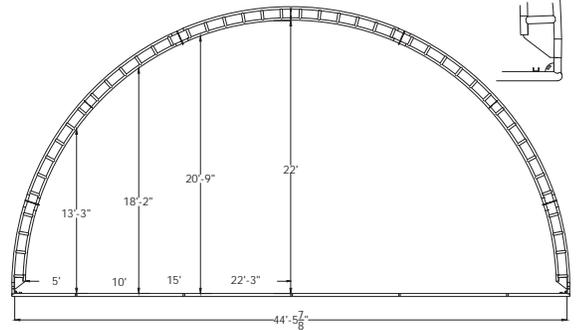

50' LOW TRUSS BUILDING

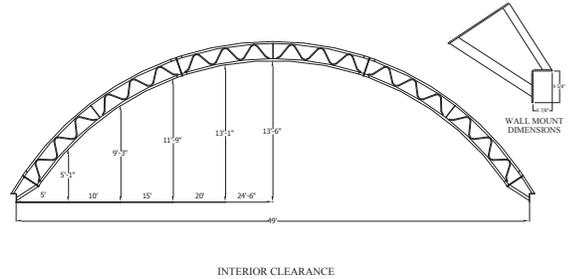

50' TRUSS BUILDING

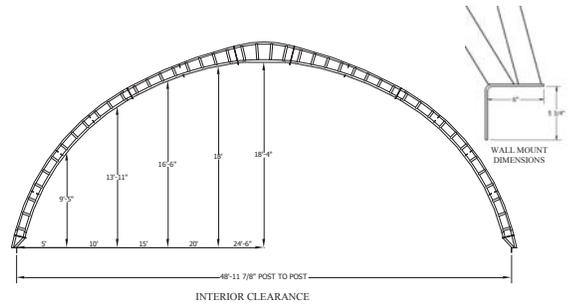

60' HP TRUSS BUILDING

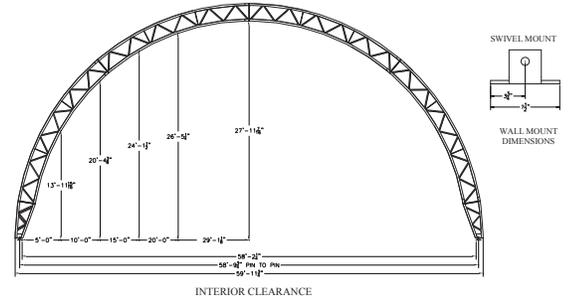

60' TRUSS BUILDING

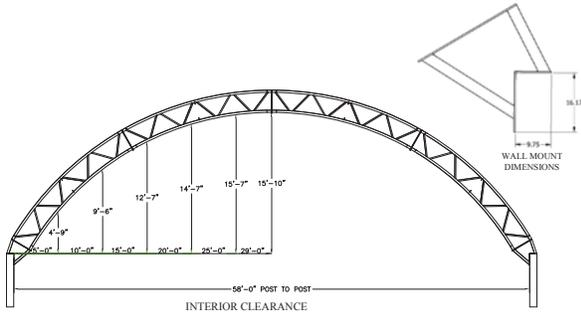

120' TRUSS BUILDING

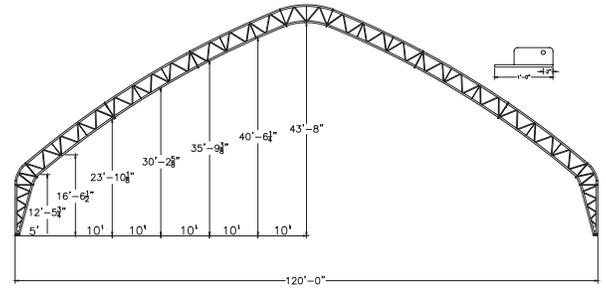

70' HP TRUSS BUILDING

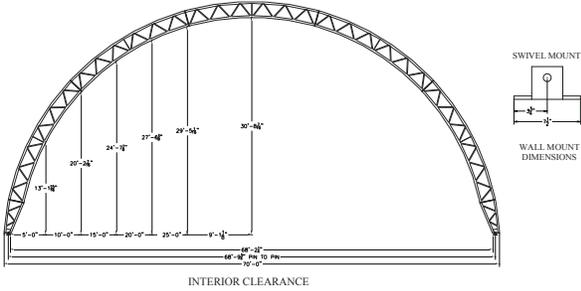

140' TRUSS BUILDING

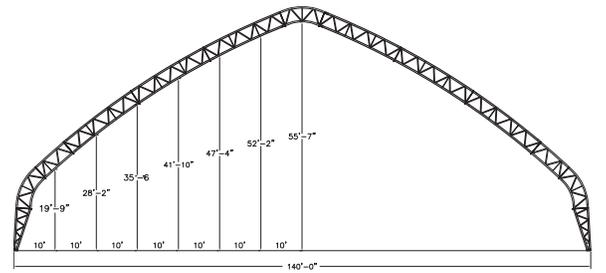

70' TRUSS BUILDING

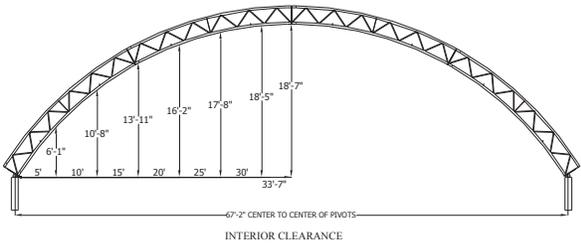

80' TRUSS BUILDING

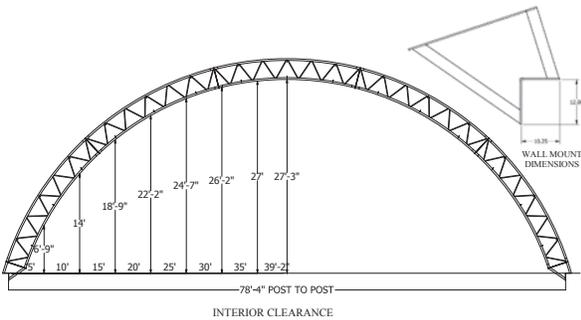

100' TRUSS BUILDING

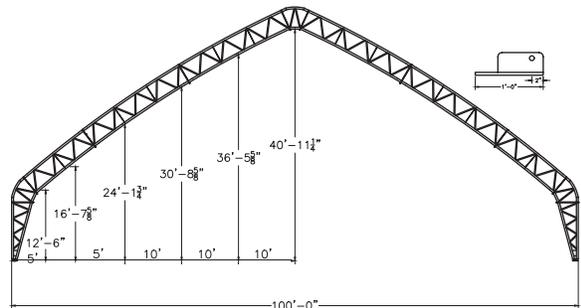

WWW.RUSH-CO.COM • Rush-Co Rushmore Buildings Catalog • Rush-Co reserves the right to change products as required

COVERS FOR ALL BRANDS!

CATTLE/DAIRY FACILITIES

WWW.RUSH-CO.COM • Rush-Co Buildings Catalog • Rush-Co reserves the right to change products as required

Rushmore Buildings have become popular among livestock producers due to their cost and labor saving features. As beef and dairy operations continue to grow and expand, larger and more economical solutions are needed for housing your livestock. Providing a safe and secure environment for your livestock is the goal of any feedlot manager.

Comfort is the key to any beef operation, for your herd as well as for yourself. With a building from Rushmore Buildings, you can take reassurance in the fact that your cattle will be less stressed, more relaxed and a lot more comfortable than in an outdoor feedlot. The casual, positive environment means your cattle will have a greater chance at higher, faster weight gain, and that can mean more profit for you.



RUSHMORE BUILDINGS
provide a **solution** to help **protect your livestock & benefit your productivity.**



EQUIPMENT STORAGE BUILDINGS

Maintain the value of your equipment by storing it in a Rushmore Building. Protecting your equipment from the extreme elements will preserve the equipments appearance and help maintain its retail value, along with saving you time and money on repairs of bearings, belts, and hoses.

- Quick installation and convenient maintenance
- Fast, affordable protection for your agriculture and multi purpose use
- Can be installed on numerous foundation types to best suite your site and location
- Engineered to offer years of low cost and dependable service



WWW.RUSH-CO.COM • Rush-Co Rushmore Buildings Catalog • Rush-Co reserves the right to change products as required

COVERS FOR ALL BRANDS!

SALT/FERTILIZER STORAGE

Let Us Cover what You Value!



Our steel framed, fabric-covered buildings are an economical solution to cover what you value for additional storage and space.

Protecting your commodities from the elements is crucial in all seasons regardless of the current market value. Rushmore Buildings free-span interior ensures maximum useable space for salt and fertilizer storage with increasing maneuverability inside the building. The natural light provided by our fabric cover on Rushmore Buildings allow for energy savings throughout the year. Our hot dipped steel truss provides great protection against highly corrosive salt and fertilizer.



WWW.RUSH-CO.COM • Rush-Co Buildings Catalog • Rush-Co reserves the right to change products as required



This temporary Rushmore Building combines a heavy rigid truss and a high quality cover which is great for storing and protecting vehicles and machinery. This portable building allows for quick and easy relocating.

For pricing options, please request a Quote or call us at 1.866.776.5617

Benefits of the Free-Standing Building

- Easy to relocate when your individual needs change
- Can be built on any flat surface
- 12.5 oz woven high-density polyethylene coated fabric
- Ratchets-and-pipe offer a secure tie down
- Anchored to the ground by 8" x 3' auger ground anchors

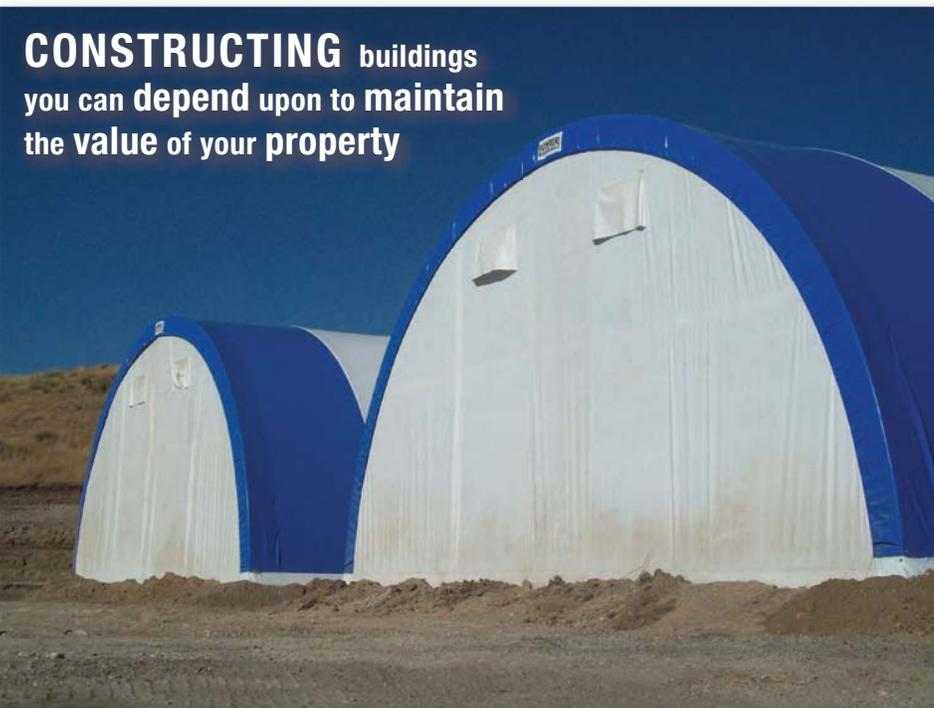

WWW.RUSH-CO.COM • Rush-Co Rushmore Buildings Catalog • Rush-Co reserves the right to change products as required

MONO-TUBE BUILDINGS

Structures can easily be modified to best suit your needs



Rush-Co reserves the right to change products as required

Rush-Co Rushmore Buildings Catalog

WWW.RUSH-CO.COM